



HRVS-DN

Medium Voltage Soft Starters

2300 - 13800V, 60-1200A

Instruction Manual



September 2006

Safety

- Read this manual carefully before operating the equipment and follow the instructions.
- Installation, operation and maintenance should be strictly accordance with this manual, national codes and good practice. Installation or operation not performed in strict accordance with these instructions will void manufacturer's warranty.
- Disconnect all power inputs before servicing the soft-starter and/or the motor.
- After installation, check and verify that no parts (bolts, washers, etc) have fallen into the power Section (IP00).

Attention

1. This product was designed for compliance with IEC 947-4-2 for class A equipment and EN 50178.
2. For further information see Technical Specification

Warnings

- Internal components and P.C.B's are at main potential when the HRVS-DN is connected to main voltage. This voltage is extremely dangerous and will cause death or severe injury if contacted.
- When HRVS-DN is connected to the main voltage, even if control voltage is disconnected and motors is stopped, full voltage may appear on starter's output and motor's terminals.
- Unit must be grounded to ensure correct operation, safety and prevent damage.
- Check that Power Factor capacitors are not connected to the output side of the soft starter and confirm that they are connected upstream to the line contractor.

The company reserves the right to make any improvements Or modifications to its products without prior notice.

Table of Contents

Page	Subject
3	Starter Selection
4-5	Installation
6-7	Internal Setting
8-9	Control Terminals
10	Control Terminals – Option Boards
11-12	Control Wiring
13	Wiring Diagrams
14	Wiring Diagrams Diesel Generator
15-16	Wiring Diagrams – Communication
17-18	Start & Stop Parameters
19-20	Motor And Starter Protection
21	Motor And Starter Protection Occurrence Table
22	Standard wiring Diagram
23	Front Panel
24	Display Mode
25-31	Parameter Settings
32	Start-Up Procedure
33-35	Menu Description
36-37	Trouble Shooting
38-39	Technical Specification

Starter Selection

The HRVS-DN is a highly sophisticated and reliable starter designed for use with standard medium voltage three-phase, three-wire, squirrel cage induction motors. It provides the best method of reducing current and torque during motor starting.

The HRVS-DN starts the motor by supplying a slowly increasing voltage to the motor, providing soft start and smooth acceleration, while drawing the minimum current necessary to start the motor.

The second generation, microprocessor based digital circuitry provides unique features like pump control, accurate motor protection and optional analog output.

The optional RS485 Communication with MODBUS, PROFIBUS and other (consult factory) protocols enables full control (Start, Stop, Dual Adjust, command, etc.) and supervision. Up to 32 starters or other MODBUS slaves can be connected on a shield twisted pair to a host computer.

Motor Current & Starting Conditions

Select the starter according to motor's Full Load Ampere (FLA) – as indicated on its nameplate (even if the motor is not fully loaded).

The HRVS-DN is designed to operate under the following conditions:

- Max. ambient temp: 50°C
- Max. starting current: 400% motor's FLA
- Max. starting time: 30 sec. (at 400% FLA)
- Max. starts per hour: 2 starts per hour at maximum conditions.

PIV (Peak Inverse Voltage) Ratings

PIV Rating will be not less than:

<u>System Voltage</u>	<u>PIV Ratings</u>
2300V	6900V
3300V	12500V
4160V	12500V
6600V	19500V
11000V	39000V
13800V	41000V

Main Voltage (line to line)

Thyristors PIV rating, internal circuitry and insulation defines the following voltage levels:

2300V, 3300V, 4160V, 6000V, 6600V, 6900V, 11000V and 13800V.

Each starter is suitable for 50/60Hz.

Control Voltage

The Control voltage operates the electronic circuitry. The following voltage levels are available:

- 220-240V + 10%-15%, 50/60 Hz (standard)
- 110-120V + 10%-15%, 50/60 Hz
- 110 VDC (optional)
- Consult factory for special voltages.

Control Inputs

Control Input voltage (start, stop, etc.) can be the same as Control Supply above (standard), or 24-240V AC / DC (by special order).

Options (see Ordering Information Data)

- Analog card - analog output (option # 5)
- Tachometer feedback (option # T)
- Relays card:
 - enable to operate via communication.
 - to get an up to speed signal when starting synchronous motors if the by pass contactor is close or $I_n < 115\% I_n$
- Multi start configuration
- LLOYD'S approval for marine application
- Customized cabinet arrangement.

Installation

Prior to Installation

Check that Motor Full Load Ampere (FLA) is lower than or equal to the starter Full Load Current (FLC) and that the Main and Control voltages are as indicated on the front panel.

Mounting

- The starter must be mounted vertically.
- Do not mount the starter near heat sources.
- Protect the starter from dust and corrosive atmospheres.

Temperature Range and Relative humidity

The starter is rated to operate within the temperature range of -10°C (14°F) to + 50°C (122°F). Relative humidity inside the enclosure should not exceed 95% non-condensed.

Do not interchange line and load connections.

Short Circuit Protection

For short circuit protection use M.V. fuses.

Transient Protection

When high transients are expected, external protection should be used (consult factory).

WARNING

Power factor correction capacitors, if required must be installed on the line side of the HRVS-DN

Do not connect three phase voltage without starting the HRVS-DN for more than 30 seconds.

Power Section Connections

- **Line** to terminals L1, L2 and L3.
- **By-pass** to terminals L1b, L2b and L3b.
- **Motor** to U, V and W.
- Line and By-pass contactors must be used.
- Power Factor Capacitors, if required, should be installed on the HRVS-DN line side (not on the HRVS-DN Load side).
- Main supply must be applied in the correct phase sequence.
- Bus bars and bypass contactor must be arrange to maintain current flow through the bypass after end of acceleration process. Otherwise, current protection of the soft starter will not function.
- Interlock the serial contactor - starting relay with the “Fault relay” of the HRVS-DN.

Internal Settings

Control Module for HRVS-DN is **identical for all ratings** and suitable for mounting in L.V. Compartment

Control Module Connection

- Install the module in the L.V. compartment, which should be fully segregated from the H.V. compartment.
- Ensure that Control Module is properly grounded.
- Connect interposing relays to all HRVS-DN auxiliary contacts, three relays must be incorporated: Run, Fault and By-pass.
- Fiber-optic technology is used to control the soft-starter's firing signals. Six fiber optic leads are connected to the firing boards on the Power Section and should be connected to the Fiber Optic connectors on the Control Module.
- Follow the fiber optic installation directions carefully and accurately at the end of the commissioning process.
- The leads are marked with numbers from 1-6, insert each lead to its own receptacle.

Fiberoptics Connections

1. Release fiber-optic nut CCW ½ a turn.
2. Remove 25mm fiber-optic lead from the insertion hole.
3. Identify the numbers for the F/O on the leads.
4. Insert Fiber-optic leads to their maximum (about 18mm).
5. Tighten fiber-optic nut gently, CW direction, ½ a turn.

Fiberoptics Board

Front view of the fiber-optic board. Fiber-Optic board dip - switches are located below f/o insertion connector # 5.

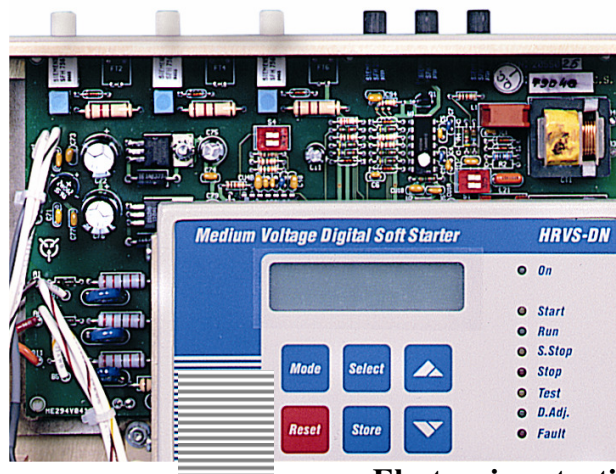

Electronic potential transformer (EPT)

Note:

Make sure the wires are connected according the marked number

Input:

Directly connected to H.V. bus bars

Input:

Power supply with fused connector

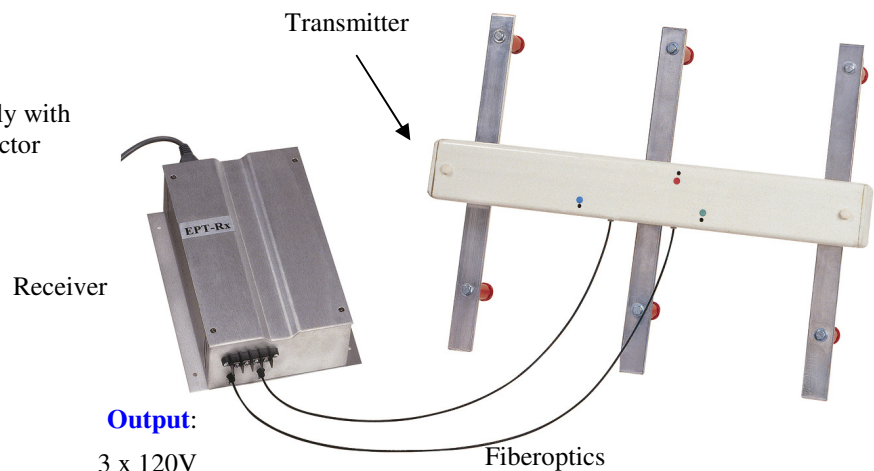

Internal Settings

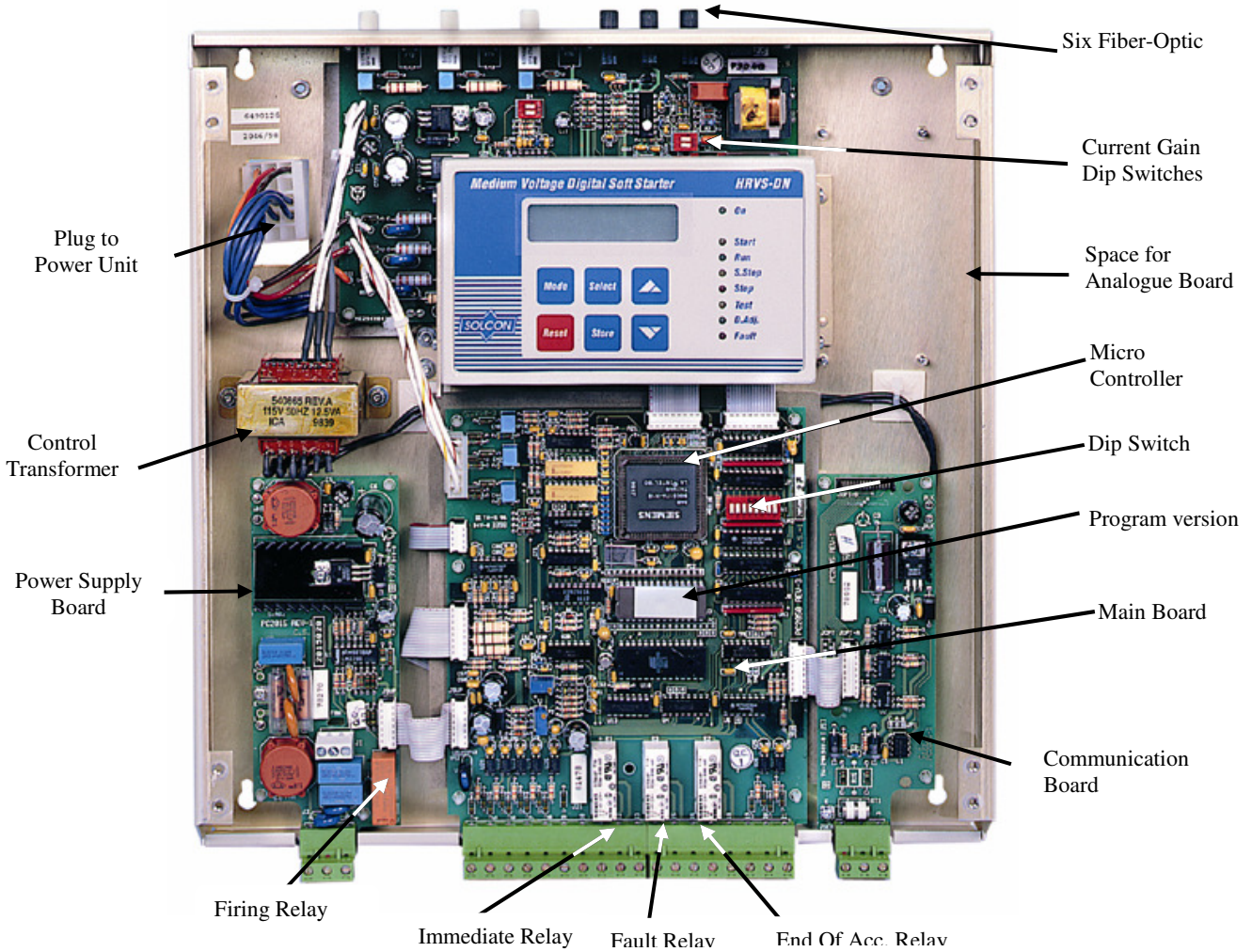

Built-in memory systems

The HRVS-DN incorporates 3 memory systems:

- EPROM** A read-only, non-volatile memory, containing factory set parameters (default) that cannot be changed.
- EEPROM** A read/write, non-volatile memory, where field adjusted parameters, statistical and fault data are saved and stored.
- RAM** A read/write memory containing parameters loaded from the EEPROM which can be changed from the keypad. These parameters are stored only as long as Control Supply is connected.

Memory system operation

1. When Control Supply is switched on, the RAM is automatically loaded from the EEPROM and parameters are displayed on the LCD.

2. Parameters can now be modified from the keypad (if starter is in one of the operating modes and software lock is open – Dip Switch 8 open).
3. Start parameters can be modified during starting process and will immediately affect the operation. Example: if Current Limit is set too low and motor does not accelerate to full speed, increasing the Current Limit setting will immediately affect the start process. This enables selection of the optimal starting characteristics.
4. After completion of the adjustments, parameters should be stored in the EEPROM. Storing of new parameters is possible at the end of each Mode Page by pressing Store key after “Store Enable” is displayed on the LCD.

Test Modes:

Three modes of test are available:

1. Test condition where the soft starter is tested for correct logical operation without Medium Voltage connected to it.
2. Firing test requires only control voltage without main voltage.

Internal Settings

3. Test condition with test harness and four pairs of dip - switches allowing a 400V motor test.

Dip Switch settings (PC2050)

The Dip Switch module contains eight separate switches and located under the front cover of the Control Module.

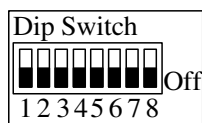

When necessary, carefully open the front panel and set the switches as required.

Note: All switches are factory pre-set in OFF position.

No	Switch Function	Switch Off	Switch On
1	Display Format	Minimized	Maximized
2	Tacho feedback	Disabled	Enabled
3	Main / Generator	Main	Generator
4	Must be Off		
5-6	LCD-language selection	See table	
7	Special settings – keep in Off position	Disabled	Enabled
8	Software lock	Open	Locked

Switch # 1 – Display Modes

For operation convenience there are two display modes:

Maximized – Display of all possible parameters.

Minimized – Display of pre-selected parameters.

Setting Dip Switch # 1 to Off will minimize the LCD displays.

Maximized mode

Switch 1 – On

Display only
Main parameters
Start parameters
Stop parameters
Dual adjustment
Fault parameters
I/O programming
Communication parameters
Statistical data

Minimized mode

Switch 1 – Off

Display only
Main parameters
Start parameters
Stop parameters
Statistical data

Switch # 2 – Tacho feedback (Optional)

Set Dip Switch. # 2 to On, when using Incremental Shaft Encoder or tacho feedback.

Note: To operate tacho feedback – consult factory for specific settings for each application.

Switch # 3 – Main / Generator control

When starting from a diesel – generator supply, starting process can sometimes terminate due to instability of the supply system. To operate generator mode set Dip Switch # 3 to On and special starting characteristics, suitable for Diesel Generator supply – with unstable voltage & frequency become operative. Closure of Dual Adjustment contact (terminal 8) operates the special starting characteristics.

When operating from network voltage and alternatively from diesel generator, set normal starting characteristics for Main and suitable parameters for the Diesel Generator (for example, faster acceleration, lower current limiting, etc.) on Dual Adjustment setting.

WARNING

When operating in Generator Mode, or with curve “0” motor must be loaded, otherwise, vibration may occur during starting and stopping.

Switches # 5, 6 – Language Selection

Language	Switch 5	Switch 6
English	Off	Off
French	Off	On
German	On	Off
Spanish	On	On



Switch # 7 – Special settings – consult factory

WARNING

When using extended Soft-Starter range, apply maximum precautions to avoid motor or starter damage.

Switch # 8 – Software Lock

The software lock prevents undesired parameter modification.

To verify that parameters are locked, press Store and  or  keys and the LCD displays, “Unauthorized Access”.

Control Terminals

Control SupplyTerminals 1-3
 110-120V or 220-240V, 50/60Hz as indicated on the front panel is required to power the electronic circuitry. This voltage can be supply from a grounded or ungrounded main system. It can be supply by special order for 110VDC.

Note: It is recommended that terminals 1-3 be continuously connected to the Control Supply.

Firing Supply Outut..... Terminal 2
 Output of control voltage (from terminal 1) to energize the firing transformer. Operates during soft start and soft stop of the soft starter.

Control Inputs

Incorporating opto - couplers to isolate the micro - processor circuitry can be the same voltage as Control Supply above, 110-120 or 220-240V, 50/60Hz. By special order it can be supply for 24-110VDC.

Note: The HRVS-DN is supplied as standard with the same voltage for Control Supply & Control Inputs.

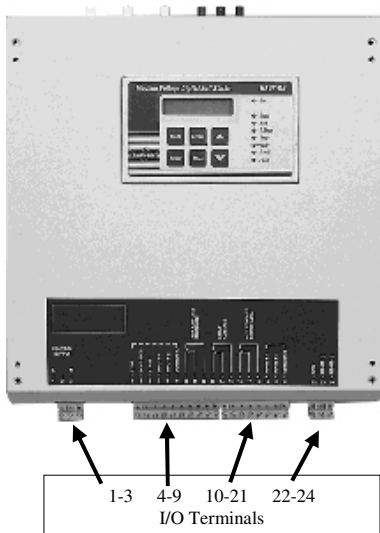

Stop..... Terminal 4
 Input from a N.C contact. To stop the motor, disconnect control voltage from Terminal 4 for at least 250mSec.

Soft stop..... Terminal 5
 Input from a N.C contact. To soft stop the motor, disconnect control voltage from Terminal 5 for at least 250mSecs.

Note: If Soft-Stop is not required, connect a jumper between terminals 4 and 5.

Start..... Terminal 6
 Input from a N.O contact. To start the motor, connect control voltage to Terminal 6 for at least 500 mSecs.

Notes:

1. Motor will start only if Stop (4) and Soft Stop (5) terminals are connected to control voltage.

2. Reset after a fault is not possible for as long as Start command is present.
3. HRVS-DN ignores start within 3 sec after stop. Wait at least 3 sec before restarting.

Test / Reset.....Terminal 7

Input from a N.O contact. Selection between above functions is made from the keypad or through the communication.

- a. Test is designed to enable thyristors firing test without mains. When connected through a N.O. contact, closing the contact operates Test.
- b. When Reset function is selected, connect terminal 7 momentarily to control voltage (use a N.O **momentary** contact) to reset the starter.

Dual Adjust / Reset..... Terminal 8

Input from a N.O contact. Selection between above functions is made from the keypad or through the communication (see I/O Programming).

- a. Dual Adjustment function is selected by connecting terminal 8 to control voltage to operate starter with the Dual Adjustment characteristic. Switching between Primary and Dual Adjustment settings can be done before and during starting. If a push-button arrangement is used, keep control voltage connected at least until RUN LED is lit.

Note: When starting from a “small” Diesel Generator or weak power supply set dip switch # 3 to on and connect terminal 8 to control voltage to operate starter with Generator Parameter settings.

- c. When “Reset” function is selected, connect terminal 8 momentarily to control voltage (use a N.O momentary contact) to reset the starter.

Common A Terminal 9

Common for terminals 4, 5, 6, 7, 8.

Note: When control supply voltage and control input voltages are from the same source, connect a jumper between terminals 3 and 9.

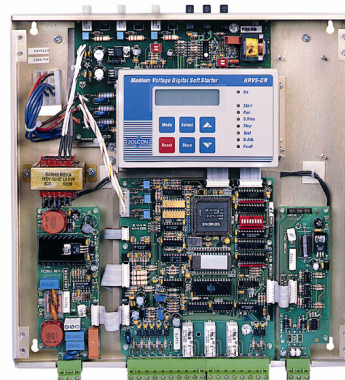

Control Terminals

Immediate/Shear-pin Relay.....Terminals 10-11-12

Terminals: 10-N.O. 11-N.C. 12 - Common.

Voltage free 8A, 250VAC max.

Selection between functions is made from the keypad or through the communication, (see I/O Programming), Programmable functions:

1. Immediate (after start signal)
2. O/C Shear-pin detection.

1. When Immediate is selected, the contact changes its position upon start signal. The contact returns to its original position upon Stop signal and in case of a fault or control supply outage.

When Soft Stop is operated, the contact returns to the original position at the end of the Soft Stop process.

The contact incorporates On & Off delays within 0 – 60 sec each.

The Immediate Contact can be used to:

- Interlocking with other systems.
- Signaling.
- Delay for opening an upstream contactor at the end of soft stop thus to allow current decrease to zero before opening the contactor.
- Switch to / from Dual Adjustment settings with a time delay from Start signal (see Special Starting).

2. When O/C Shear-pin is selected, the contact changes position upon detection of Jam condition (Starter trip can be delayed within 0-5 sec.)

The O/C Shear-Pin contact can be used to:

- Interlocking with other systems.
- Signaling
- Delay for operating a reversing combination of contactors when Jam is detected to allow a clearing of a Jam condition.

Fault Contact.....Terminals 13-14-15

Terminals: 13-N.O. 14-N.C. 15 - Common

Voltage free 8A, 250VAC, 2000VA max. changes its position on fault. The contact is programmable to function as Trip or Trip fail safe relay.

- a. When Trip function is selected - the relay is energized upon fault. The contact returns to its original position after fault has been removed and starter was reset or upon disconnection of Control Supply.
- b. When Trip-fail safe function is selected - the relay is energized immediately when Control Supply is connected and de-energizes upon fault or control Supply disconnection.

End of Acceleration Contact..... Terminals 16-17-18

Terminals: 16 - N.O. 17 - N.C. 18 - Common

Voltage free 8A, 250VAC, 2000VA max. changes its position at the end of acceleration with an adjustable time delay (Contact Delay) of 0 – 120 sec.

The contact returns to its original position on Soft Stop or Stop signals on fault condition or voltage outage.

The End Of Acceleration contact must be used to close a by-pass contactor through a pilot (interposing) relay and can be use to:

- Activate a valve after compressor has reached full speed.
- Signal, allowing for the loading of a conveyor after motor reached full speed, etc.

External Fault 1 Terminal 19

Input from a N.O contact connected between terminals 19 and 21. The starter will trip 2 seconds after contact closes.

External Fault 2 Terminal 20

Input from a N.O contact connected between terminals 20 and 21. The starter will trip 2 seconds after contact closes.

Common B..... Terminal 21

Common for terminals 19, 20

Notes:

1. When Control Supply voltage and Control Input voltage are from the same source, connect a jumper between terminals 3, 9 and 21.
2. If External inputs are not used, leave terminals 19, 20 and 21 open.

Control Terminals – Option Boards

RS-485 Communication.....Terminals 23-24

Terminals: 23 (-), 24 (+) and terminal 22 (GND).

Optional RS485, half duplex with MODBUS protocol, baud rate 1200, 2400, 4800, 9600 BPS. Twisted shielded pair should be used and shield connects to ground on the PLC/Computer side. Terminals 4 & 5 must be wired to control supply voltage for operation in communication mode (see Communication Wiring Diagrams).

Profibus

9 pin D-sub connector is available for Profibus.

Analog I/O (option # 5)Terminals 28-32

- Terminals 28-29 leave open
- Terminal 30 – Ground (leave open)
- Terminal 31 – Analog output (-)
- Terminal 32 – Analog output (+)

The Analog card output incorporates two functions (Voltage & Current outputs).

Dip switches allow selection between:
0-10VDC, 0-20 mA and 4-20 mA

The Analog value is related to the motor current and can be programmed to normal or inverted output. (Default = Normal)
Maximum value (20mA or 10Vdc) is related to 2 x In.

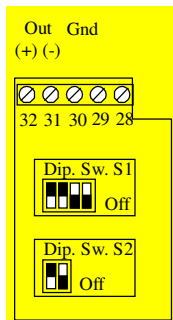

Dip switch No.	4-20 mA*	0-20 mA	0-10VDC
Dip-Switch S1 # 1	On	On	Off
Dip-Switch S1 # 2	On	On	Off
Dip-Switch S1 # 3	Off	Off	On
Dip-Switch S1 # 4	Off	Off	On
Dip-Switch S2 # 1	On	Off	Off
Dip-Switch S2 # 2	No use	No use	No use

* Default

Relays board

The board includes two relays that enable:
1) Operation and control of starter cabinet via communication.
2) Up to speed relay, which energizes when By Pass contactor is closed and current reduced below 115% of FLA. The relay remains latched until motor stopped.

Tacho board

This option is suitable to use with incremental shaft encoder. Consult factory

Control Wiring

1	Control supply	
2	Firing Supply output	
3	N- control supply	
4	Stop	
5	Soft Stop	
6	Start	
7	Input #1-Test/ Reset	
8	Input #2-D. Adjust/ Rese	
9	Common A (of 4..8)	
10	Immediate/O.C shear pin Relay	
11		
12		
13	Fault Relay	
14		
15		
16	End Of Acceleration Relay	
17		
18		
19	Input #3-Ext. Fault 1	
20	Input #4-Ext. Fault 2	
21	Common B (of 19..20)	
22	Leave Open	} Optional
23	(-) RS 485	
24	(+) RS 485	
30	Leave Open	} Optional
31	(-) Analogue	
32	(+) Analogue	
41	Insulation test	} Optional
40		
42		
Leak		

Analogue card

Note: One of the cards can be installed.

Relays Board

31	Comm. Start/ Stop
32	
33	"Up to speed" relay
34	
35	

Notes:

- Standard control and input voltage are 115 or 230VAC.
DC Supply sources available by special order.
See ordering information and consult our factory.

- If External faults are not used leave terminals 19, 20, 21 open.

A 10A fuse must protect control Supply.
It is recommended to use a separate fuse for the auxiliary circuits.

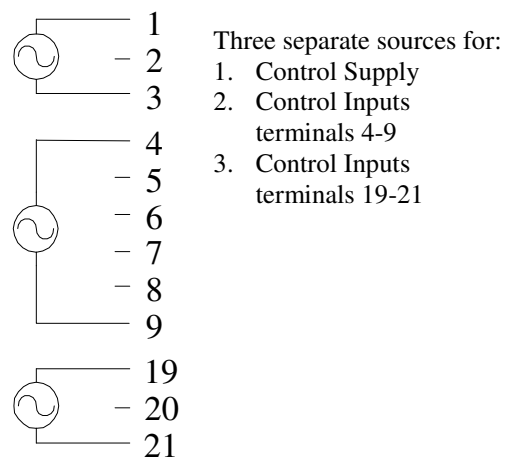
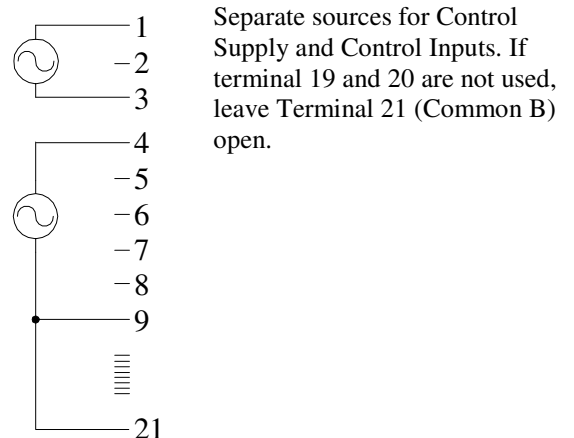
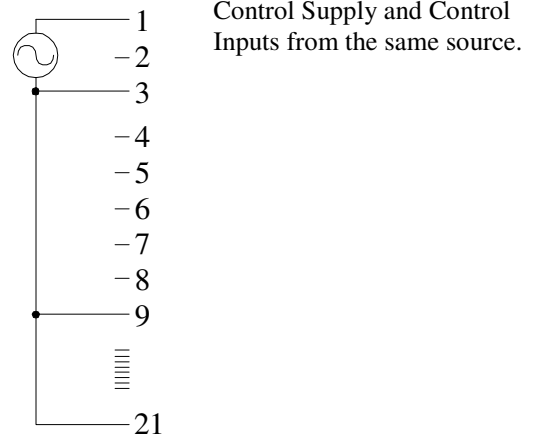

Control Wiring

1. Motor will soft start when C closes and stop immediately when C opens.

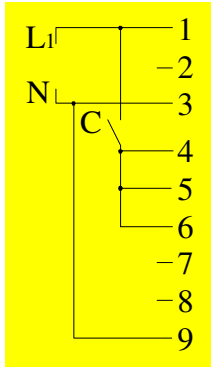

2. Motors will soft start and soft stop with C.

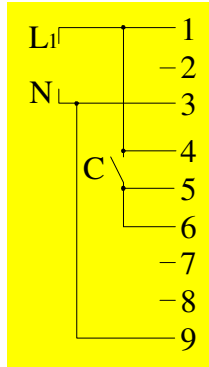

3. Motors will soft start and soft stop with C. C₁ act as emergency stop.

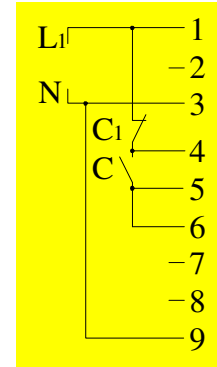

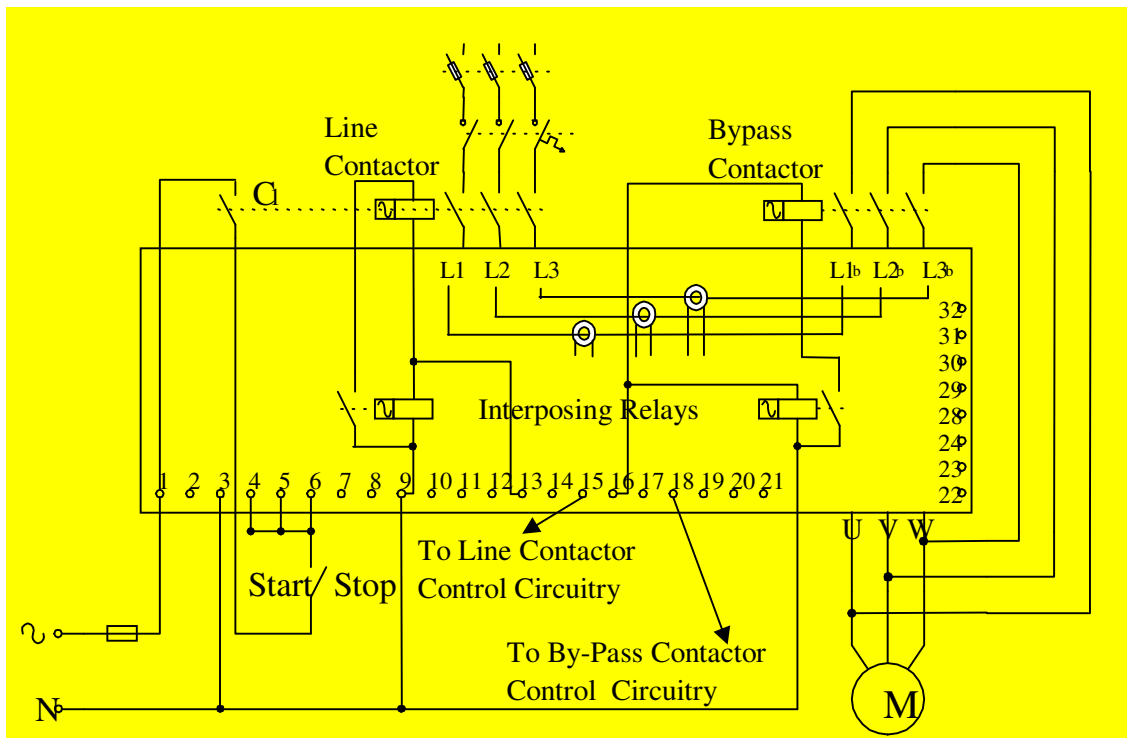

Series contactor

- A Line contactor and by-pass contactor must be used
- To incorporate soft stop, use Run contact off delay to “Hold” the Line Contactor.

This system is used mainly when the HRVS-DN is retrofitted into an existing system, thus, reducing modifications in existing installations. Main power and Start signal are switched on upon closure of the series contactor. The starter will operate as long as the series contactor is closed.

Notes:

1. It is recommended that terminals 1-3 shall be always connected to Control Supply.
 2. Upstream contactor must be opened immediately after soft stopping. The upstream contactor can be interlocked via the Immediate Contact that changes its position only at the end of soft stop. It is therefore recommended to delay the opening of the upstream contactor for a few seconds after the completion of soft stop process (after current reached zero). See Immediate / Shear-pin contacts delay – page 9.
- Ensure that auxiliary contact C₁ closes together with or after the main contactor. The soft-starter provides a 500 mili seconds delay for the start signal. If it close before, Under Voltage fault will occur.

By-pass contactor

End of Acceleration contact is activated after an adjustable time delays “Run Contact Delay” – see page 26 at the end of start-up period, closing the by-pass contactor.

- By-Pass Open failure will trip the system if the By-pass contactor is connected to L1, L2 and L3 instead to L1b, L2b and L3b buses. If this type of connection cannot be avoided set By Pass open trip to DISABLE.

Warning: all current protections are lost.

The contact will return to its original position when:

- Soft Stop or Stop signals are initiated.
- Fault conditions occur.

When the by-pass contactor closes, current to the motor will flow through the by-pass. When a Soft Stop signal is given, the End of Acceleration contacts return to its original position opening the by-pass contactor. Thereafter, the voltage will gradually ramp down to zero to soft stop the motor.

Wiring Diagrams – Diesel Generator

FOR STARTING FROM GENERATOR ALWAYS TRY START CURVE 0 FIRST!

1. When starting from a Diesel – Generator, the voltage regulator (especially older type regulators) may be affected during the starting process and cause a rapid voltage fluctuations. In these rare cases, the voltage regulator must be upgraded – consult your Diesel-Generator Supplier.
2. When operating from Diesel Generator verify that power factor capacitors are not used.
3. In applications that may start both from generator and from mains, ensure that power factor capacitors, if used, are disconnected before starting from the generator.
4. Ensure that Diesel Generator size is suitable. It is recommended that Generator KVA is 2.5 times motor KVA or larger.

WARNING

1. Motor can not run idle and must be loaded when operating in Generator Mode, otherwise vibration may occur during starting and stopping.
2. When using extended range, use maximum precaution to avoid motor or starter burnout.
3. Disconnect all other loads before starting for the first time to prevent damages due to voltage fluctuations.
4. Disconnect Power Factor capacitors when operating with Diesel Generator

Wiring Diagrams - Communication

Operation via communication link with Local / Remote selector switch

- Remote: via Communication Link
- Local: Soft-start, soft-stop by maintained contact.

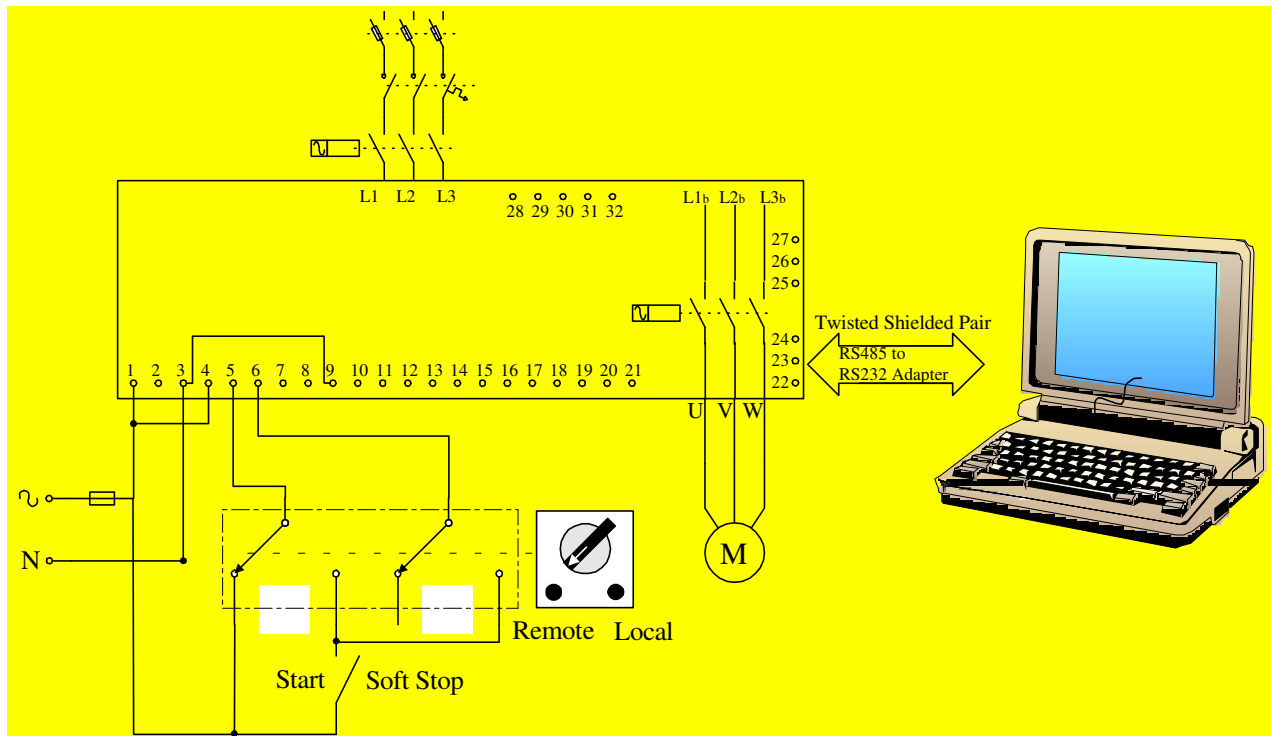

The communication enables remote parameter settings and readings. For start, stop, soft-stop, dual adjust, etc. terminals 4 and 5 must be wired as shown.

Soft-start and soft-stop

- Program the “Serial Link Number” in the communication page according to the protocol manual.
- Disconnect control supply, so the new information will be loaded on the next time you turn it on.
- Connect a communication line (twisted shield pair) with its (+) to HRVS-DN terminal 24 and (-) to terminal 23, on MODBUS, connect the other end to your host computer containing RS-485 communication port with MODBUS protocol. For other protocols – consult factory
- Connect other HRVS-DN terminals as follows:
 1. Terminal 1, 3 and Control Supply
 2. Terminal 4 to Control Supply phase
 3. Terminal 9 to Common for terminals 4, 5, 6.
 4. During operation via communication link, terminal 5 is connected through the “Local-Remote” selector switch to Control Supply and start-stop commands are controlled through the communication port.
During operation in Local mode, terminals 5 and 6 are connected to Control Supply through the start/soft-stop toggle switch.

WARNING

Starter and host computer must be grounded when communicating with HRVS-DN

Wiring Diagrams - Communication

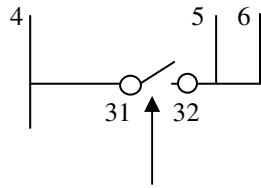

Soft-start and immediate stop

Same as the explanation for soft-start and soft-stop except # 4:

4. During operation via communication link, terminals 4 and 5 are connected through the Local / Remote \ Comm. 4 position selector switch to Control Supply and start-stop commands are controlled through the communication port.
During operation in Local mode, terminals 4, 5 and 6 are connected to Control Supply through the start-stop toggle switch.

Soft-start, soft-stop and immediate stop

Same as the explanation for Soft-start and soft-stop except # 2 and # 4:

2. Connect terminal 4 as described above.
4. During operation via communication link, terminals 4 and 5 are connected through push-buttons to Control Supply and start / stop commands are controlled through the communication port.
During normal operation mode, terminals 4, 5 are connected to Control Supply through the immediate stop and soft stop push buttons. Soft start command may be initiated by pressing the start push button.

Notes: The communication (data retrieval and statistics) is active at all time!

If control signals (start, stop, etc.) are required, terminals 4 and 5 have to be wired in accordance with the appropriate wiring diagram:

1. Maintained soft start and stop.
2. Maintained soft start with immediate stop.
3. Soft start / stop with immediate stop via push-button control.

Relays board

The relay board enables to control the soft starter via communication with MODBUS or PROFIBUS.

Operation via communication link with Local \ Remote \ Communication (Selector switch)

- Local - to soft-start or immediate stop by maintained contact.
- Remote - via PLC link or other remote signal.
- Comm. - Operation via communication link.

Contacts 31-32 control by communication through the following protocols:

PROFIBUS

- 1) Operating the contact for Start \ Stop signal.
- 2) D. Adj. Calibration.
- 3) Reset the soft starter.

MODBUS

With MODBUS protocol it is possible to calibrate the parameters as well as operating the unit like with PROFIBUS protocol

Start & Stop Parameters

Pump Control – Start Curves

Induction motors produce peak torque of up to 3 times the rated torque towards the end of starting process. In some pump applications, this peak may cause high pressure in the pipes.

The HRVS-DN incorporates 5 different starting curves:

Start Curve 0 – Basic curve. Uses less feedback signals.

Use at beginning of commissioning and when other curves do not give good starting process.

Start Curve 1 – Standard curve (Default). The most stable and suitable curve for the motor that prevents prolonged starting and motor overheating.

Start Curves 2, 3, 4 – During acceleration, before reaching peak torque, the pump control program automatically controls the voltage ramp-up to reduce peak torque.

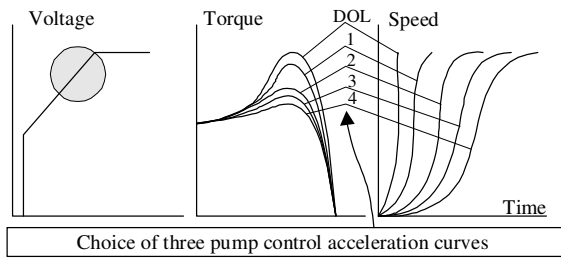

Start Curve 5 – Torque curve. Provides linear torque control. With certain loads, may cause linear acceleration.

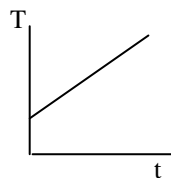

Note: Normally starts with Start Curve 1. If towards the end of acceleration, the peak torque is too high (pressure is too high), proceed to Curve 2 then 3 or 4 if necessary.

Pulse Start

This feature includes two settings:

- Pulse Level [% of FLA]
- Pulse Time [sec.]

These settings allow to use the pulse:

- To start high friction loads, requiring high starting torque for a short time.
- “Pedestal starting” – holding the current at a required level for some time.

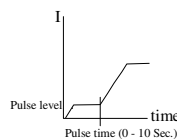
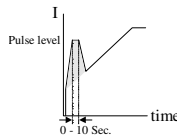

After the end of the pulse time voltage is ramped down/up to the current determined by the initial voltage setting.

Note: Pulse Start has no effect with Start Curve = 0.

Initial Voltage / Current

Determines the motor initial starting torque (the torque is directly proportional to the square of the voltage). Range: 10-50% U_n (consult factory for extended range).

This adjustment also determines the inrush current and mechanical shock. A setting, which is too high, may cause high initial mechanical shock and high inrush current (even if current limit is set low as the Initial Voltage setting overrides Current Limit setting).

A setting that is too low may result in prolonged time until motor begins to turn. In general, this setting should ensure that the motor begins turning immediately after start signal.

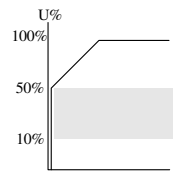

If the initial voltage value is increased above the max value, first line message changes to initial current. Setting range is 100%-400% of motor FLA. When initial current is set, starter causes current ramp instead voltage ramp.

Current limit

Determines the motor highest current during starting. Range 100-400% of FLA setting (consult factory for extended range). A too high setting will cause greater current drawn from main voltage and faster acceleration.

A setting that is too low may prevent motor from completing acceleration process and reaching full speed. In general, this setting should be set to a high enough value in order to prevent stalling.

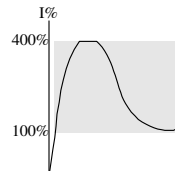

Note: Current limit is not operating during Run and soft stop.

Acceleration Time

Determines the motor voltage ramp-up time from initial to full voltage. Range 1-30 sec. (consult factory for extended range). It is recommended to set acceleration time to the minimum acceptable value (approx. 5 sec).

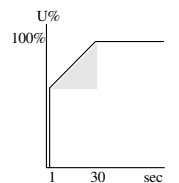

Notes:

- Since current limit overrides acceleration time when current limit is set low, starting time will be longer than the preset acceleration time.
- When motor reaches full speed before voltage reaches nominal voltage, acceleration time setting is overridden and cause the voltage to ramp-up quickly to nominal.
- Starting curves 1, 2, 3 prevents quick ramp up.

Start & Stop Parameters

Maximum Start Time

The maximum allowable starts time from start signal to the end of acceleration. If voltage does not reach full voltage during this time (for example, because of low current limit setting), the starter will trip the motor. LCD displays “Long Start Time” message. Range: 1-30 sec (consult factory for extended range).

Contact Delay

Time delay for the End of Acceleration contact after completion of starting process. Range: 0-120 sec.

Pump Control – Stop curve

Intended to prevent water hammer during stopping. In pump applications, load torque decreases in square relation to the speed and reducing the voltage will reduce torque so motor will smoothly decelerate to stop.

The following **Stop curves** can be selected:

Stop curve 0 – Basic curve. See note at page 17.

Stop curve 1 – Standard default curve – voltage is linearly reduced from nominal to zero.

Stop curves 2, 3, 4 – In some pump applications, when pumping to a high level, a considerable part of the torque is constant and does not decrease with speed. It may happen that during soft stop, when voltage decrease, motor torque quickly falls below load torque and motor will abruptly stall instead of smoothly decreasing speed to zero.

Curves 2, 3, 4 designed to prevent stall condition.

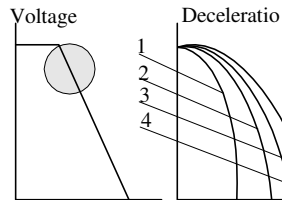

Note: Normally use stop curve 1. If motor stalls quickly instead of slowly decreasing its speed, select stop curve 2, then 3 or 4 if necessary.

Stop Curve 5 – Torque curve. Provides linear torque control. With certain loads, may cause linear deceleration.

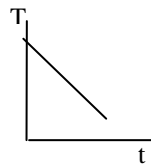

Tacho Feedback, Incremental Shaft Encoder (Optional)

Provides linear acceleration and deceleration curves according to rpm feedback. 12 tacho gain levels can be selected for closed loop control starting and stopping.

Note: Consult factory for additional information.

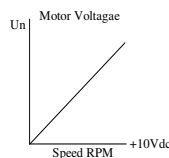

Deceleration Time – Soft Stop

Used for controlled deceleration of high friction loads. Determines motor voltage ramp down time. Range: 0-30 sec. (consult factory for extended range).

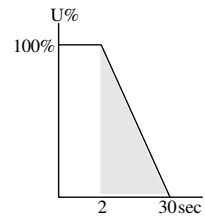

Note: soft stop initiation opens the End Of Acceleration contact and opens the by-pass contactor. Load will be transferred to the HRVS-DN and voltage begins to ramp down.

Final Torque

Determines torque towards the end of soft stop. If current is still flowing after speed is softly reduced to zero, increase the final torque setting.

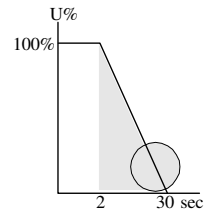

Dual Adjustment

A secondary set of parameters used for varying loads, two speed motors, etc. Connecting control supply to Terminal 8 makes transfer to Dual Adjustment settings.

- Initial Voltage 10-50% of U_n .
- Current Limit 100-400% of motor’s FLA.
- Acceleration Time 1-30 sec.
- Deceleration Time 0-30 sec.
- Motor Full Load Ampere.

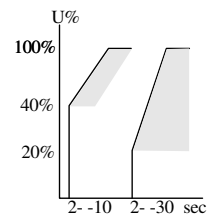

Note: Consult factory for extended range.

Motor & Starter Protection

Too Many Starts

Combines three parameters:

- **Number of Starts**
Determines the maximum allowable number of starts.
Range: Off, 1-10 starts. Default: 1
- **Start Period**
Time period when number of starts is being counted. Range: 1-60 min. Default: 20 Min.
- **Start inhibit**
Determines time period when start signal is disabled after “Too many starts” trip.
Range: 1-60 min

Note: Motor can not be started before “Start Inhibit Time” has elapsed. Trying to start the motor during this time delay will result in LCD displaying “Wait Before Restart: ___ MIN.

Long Start Time – (Stall Protection)

Trips the starter if motor does not reach full speed during “Maximum Start Time”.
Range: 1-30 sec. (consult factory for extended range).

Over Current Shear-pin trip

Operational when starter is energized and has two functions:

- Trips the starter when current exceeds 850% of starter’s FLC setting in 1 cycle or less.
- 850% FLA with delay during start (850% overrides O/L settings.
- During run (after RUN LED is on) it trips the starter if current exceeds set level and time delay.
Range: 100 - 850% of motor FLA setting
Delay: 0 – 5 sec. (0=up to 200 msec)

Note: The O/C Shear-Pin trip is not intended to replace the fast acting fused. It is required to protect the thyristors (see fuse table in the appendix).

Overload (OL)

Inverse time electronic overload becomes operational when RUN LED is on.

The OL circuitry incorporates a Thermal Memory Register, which calculates the heat less the dissipation of the motor. The starter trips when the register fills up.

The thermal register resets itself 15 minutes after the motor stops.

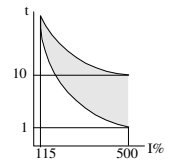

The value is adjustable within 75-150% of motor FLA and factory pre-set at 115%.

Tripping time at 500% FLA is adjustable within 1-10 seconds to allow trip curve selection.

ATTENTION

Overload protection is not operative during soft-start or soft-stop.

Under Current

Operational when motor is running. Trips the starter when motor current drops below under current trip (UCT) set point for a period of time longer than under current delay (UCD).

Under Current Trip range: 0 = Off, 20-90% of FLA
Under Current Delay range: 1-40 sec.

Auto Reset

A special feature enables auto reset after adjustable time delay. Range: Off, 10-120 min.

Under Voltage / No Voltage

Operational after start signal. It trips the starter when main voltage drops below the Under Voltage Trip set point for a period of time longer than Under Voltage Delay.

Auto reset can be activated via Fault Parameters. Auto reset is activated 60 seconds after trip occurred.

Under Voltage Trip range: 50-90% Un (Line to Line)
Under Voltage delay range: 1-10 sec.

Note:

1. When voltage drops to zero (voltage outage) the starter will trip immediately, overriding the delay.
2. Auto reset can not be activated if start signal is still connected.

Motor & Starter Protection

Over Voltage

Operational after start signal. It trips the starter when main voltage exceeds the Over Voltage Trip set point for an adjustable period of time longer than Over Voltage Delay.

Range: 110 – 125% of Un (Line to Line)

Over Voltage Delay range: 1-10 sec.

Phase loss (with programmable auto reset)

Operational when starter is energized and protects motor from loss of phase. It trips the starter when one or two phases are missing. Auto reset can be activated via Fault Parameters. Auto reset is activated 60 seconds after trip occurred.

Note:

1. Phase loss might not be detected in lightly loaded motors.
2. Auto reset can not be activated if start signal is still connected.

Phase Sequence

IT trips the starter when starter is energized and phase sequence is wrong.

Shorted SCR & Wrong Connections

Operational after start signal. It trips the starter if motor is not properly connected to starter's Load terminals, when:

- Internal disconnection in the motor winding is detected.
- In case one or more SCRs have been shorted.
- Incorrect fiber - optic lead insertion.

Heat-sink Over Temperature

Thermal sensors are mounted on the heat-sink and trip the starter when temperature rises above 85°C.

External Fault 1 & 2

Operational when starter is energized. It trips the starter when an external contact closes for more than 2 sec.

Unbalance Current Trip

Operational after start signal. It trips the starter when current unbalance increases above the preset "UNBALANCE TRIP" for more than the "UNBALANCE DLY" set-point.

Range: 10-100%. Delay: 1-60 sec.

Ground Fault Trip

Operational after start signal. It trips the starter when ground current increases above the preset "GND Fault TRIP" for more than "GND FAULT DLY" set point.

Range: 10-100%. Delay: 1-60sec.

Power ON & No Start

Operational upon main voltage connection. It trips the motor when main voltage is connected to the HRVS-DN for more than 30 sec. without a start signal.

This protection can be enabled or disabled via the fault parameters setting menu.

By-pass Open

Operational when the by-pass contactor did not close after End Of Acceleration contact signaled the pilot (interposing) relay to close.

WARNING

The over temperature protection is designed to operate under normal conditions e.g. in the event of extended low overload.

Incorrect starter selection or operations frequent starting at maximum conditions or repeated starting under fault conditions can cause SCRs to overheat and fail before the heat-sink reaches 85°C to trip the thermal sensors.

Fault and Reset

When any of the above protection operates, the starter locks in a fault condition and disables thyristors firing. Fault LED lights on, fault description is displayed on the LCD and Fault Relay operates.

- For local resetting, after fault has been removed, press Reset Key.
- Remote resetting can be done through terminals 7 or 8 (see I/O Programming – page 29).

When Fault occurs followed by a voltage outage, fault condition is latched and reappears upon voltage restoration.

Note: Resetting is not possible when Start signal exists.

Auto Reset Under –voltage & Phase-loss

Under-voltage & Phase-loss faults can be set to Auto-Reset (see Fault Parameters – page 28). The starter will reset itself 60 seconds after the trip, provided that no start signal exists.

Auto Reset Under-current

Under-current fault can be set to Auto-reset (see Fault Parameters – page 28). The starter will reset itself after the adjustable "UNDER CUR. RESET" provided that no start signal exists.

By pass open trip

If By Pass is located in a separate cabinet so after BP is closed, current measurement is "0" and soft starter trips and display "BP TRIP". It is possible to disable this protection by setting BP open trip to disable (On Fault setting page).

Note: Most of the protections after By Pass is closed can be disable by setting at the fault page

Set curve to 0 – may occur seldom during starting with special conditions of mains and load. Change start (and stop if used) curve to 0.

See also fault parameters settings.

Motor & Starter Protection Occurrences Table

Timing And Occurrence	Active During			
	Start	Run	Stop	Soft Stop
Too many starts	√			
Electronic Overload		√		
Shear Pin (Jam) * Default setting				
Starter Protection – trip function at 850% FLC in less than 1 cycle.	√	√		√
Motor Protection – trip function				
During Soft Start / Soft Stop – factory set at 850% FLA with adj. time delay	√			√
During Run – adjustment 100 – 850% FLA with adj. time delay		√		
Under current		√		
Unbalance Current	√	√		√
Ground Fault Current		√		
Phase loss	√	√		√
Phase sequence	√	√		√
Under voltage. Time delay is override in case of “No-Volt”.	√	√		√
Over voltage with adjustable time delay	√	√		√
Long start time (Stall protection)	√			
Shorted SCR & Wrong connection (Load Loss)	√			√
External fault 1 & 2	√	√	√	√
SCR protection by Metal Oxide Varistors (MOV)	√	√	√	√
Starter over-temperature	√			√
Starter internal test When supply voltage is connected and LED is “On” .	√	√	√	√
PWR ON & NO STRT			√	
By-Pass Open		√		
Insulation alarm			√	
Set curve to 0	√			

Standard Wiring Diagram

Will be send upon request

Front Panel

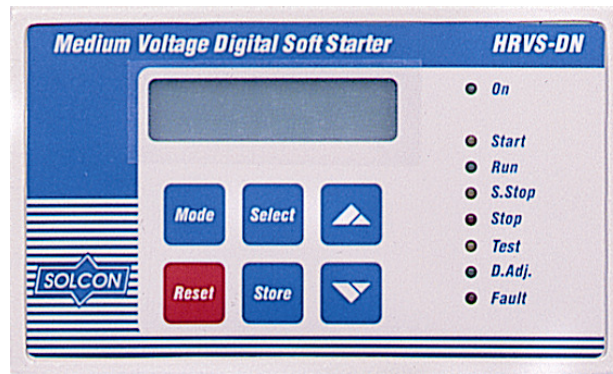

LED Arrangement

On

Lights on when Control Supply voltage is connected to the starter.

Start

Lights on during start process, indicating that motor supply voltage is ramping up.

Run

Lights on after completion of starting process to indicate that motor is receiving full voltage.

S. Stop

Lights on during soft stop process to indicate that motor supply voltage is ramping down.

Stop

Lights on when motor is stopped.

Test

Lights on when in "Test Mode" operation.

D. Adj.

Lights on when Dual Adjustment is in operation.

Fault

Lights on upon operation of any of the built-in protection.

Keypad

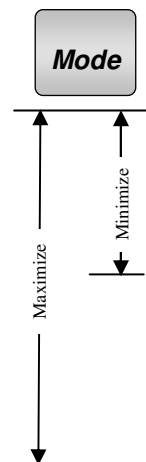

Provides selection of the following modes:

When Dip Switch 1 is in "On", gray zone shows list of maximized parameters).

- Display Only
- Main Parameters
- Start Parameters
- Stop Parameters
- Statistical Data

- Dual-Adjustment Parameters
- Fault Parameters
- I/O Programming Parameters
- Communication Parameters.

Select

To select function within each mode.

To increase adjusted parameters. Press momentarily or continuously to select forward in statistical parameters.

To decrease adjusted parameters. Press momentarily or continuously to select revers in statistical parameters.

Store

To save modified parameters.

Reset

To reset the starter after fault has been removed, canceling the displayed fault and allows restarting. Disconnect Start signal to Enable reset.

Note: Pressing Mode or Select continuously increases parameters changing speed.

Display Mode

LCD Arrangement

Two lines of 16 characters display:
System Parameters, Starter Settings, Motor Current, Insulation and Fault Identification.



Four selectable languages – English, French, German and Spanish (see Dip Switch setting – page 7).

Example:

CURRENT LIMIT 390%

- Upper line displays functions.
- Lower line displays setting and measured values.

Modifying parameters

1. Press mode key several times until you reach the required **Mode** page.
2. Press **Select** to review parameters of this mode.
3. When reaching the required parameter, modify its values with   keys.
4. To store the new parameters, press **Select** until “Store Enable” appears and then press **Store** key

Note: Pressing Mode or Select keys continuously increase parameter change speed.

Mode pages

Upon Control Supply connection, the LCD displays motor’s operating current. When Dip Switch # 1 is set to On (see Display Options) All Mode Pages can be reviewed by pressing the **Mode** key. When Dip Switch # 1 is set to off, the following Mode pages marked ** will not appear.

MAIN & PROTECT PARAMETERS
--

START PARAMETERS

STOP PARAMETERS

DUAL ADJUSTMENT PARAMETERS

FAULT PARAMETERS **

I/O PROGRAMMING PARAMETERS

COMM. DATA **

STATISTICAL DATA

In this mode, parameters are not adjustable.

I1	I2	I3	
80	80	80	%

Displays operating current as a percentage of motor’s FLA.

Note: Starter’s Default Display. A time delay is initiated after pressing **Mode** or **Select**. Following the delay, the LCD defaults back to display “% OF MOTOR FLA”. Five minutes after programming the LCD it returns to the Current Display.

Press Select –When option cards are not incorporated, the LCD displays

OPTION CARD Not Installed

When Analog card is incorporated, the LCD displays

OPTION CARD ANALOG OUTPUT

Displays analog card preset.

When Output Relays card is incorporated, the LCD displays

OPTION CARD OUTPUT RELAYS

This concluded the “Display Mode”

Pressing **Select** key at this point returns to the first display.

Obtaining “Default Parameters”

- a. Press **Mode** and  simultaneously and the LCD will display “Store Enable Default Parameters.”
- b. Press **Store** and **Mode** keys simultaneously.

CAUTION Obtaining Default Parameters will erase all previously modified settings.

HRVS-DN FLC must be set to the rated starter current as specified on the starter label.

Parameter Settings

Press Mode

To advance to:

**MAIN & PROTECT.
PARAMETERS**

Press Select

Press ▲▼ keys to set starter FLC. Range: 20 - 1400

**STARTER FLC
150 AMP**

Press Select

Press ▲▼ keys to set motor FLA. Range: 33-100% of "STARTER FLC"

**MOTOR FLA
150 AMP**

Press Select

Press ▲▼ keys to Under Current Trip set point. Range: 0 = OFF, 20-90% of FLA

**UNDERCURR. TRIP
0% OF FLA**

Press Select

Press ▲▼ keys to under Current Trip time delay set point. Range: 1-40 sec.

**UNDERCURR. DELAY
10 SEC.**

Press Select

Press ▲▼ keys to Over Current Shear-pin set point. Range: 100 – 850% of FLA

**O/C – SHEAR PIN
850% OF FLA**

Press Select

Press ▲▼ keys to set O/C Shear-pin time delay. Range: 0-5 sec.

**O/C DELAY
0.5 SEC.**

Press Select

Press ▲▼ keys to set Overload Current Trip. Range: 75-150% of FLA

**OVERLOAD TRIP
115% OF FLA**

Press Select

Press ▲▼ keys to set Overload Trip time delay at 500% of motor FLA.

Range: 1-10 sec.

**OVERLOAD DELAY
4 SEC – AT 5 FLA**

Press Select

Press ▲▼ keys to set Unbalance Trip.

Range: 10-100% of motor FLA, Off.

**UNBALANCE TRIP
20%**

Press Select

Press ▲▼ keys to set Unbalance Trip time delay.

Range: 1-60 sec.

**UNBALANCE DELAY
5 SEC.**

Press Select

Press ▲▼ keys to set Ground Fault Trip

Range: 10-100%, Off.

**GND FAULT TRIP
20% OF FLA**

Press Select

Press ▲▼ keys to set Ground Fault Trip Delay.

Range: 1-60 sec.

**GND FAULT DELAY
5 SEC.**

Press Select

Press ▲▼ keys to set Under Voltage Trip

Range: 50-90% of Un.

**UNDERVOLT. TRIP
70% of Un**

Press Select

Press ▲▼ keys to set Under Voltage Trip time delay.

Range: 1-10 sec.

**UNDERVOLT. DELAY
5 SEC.**

Press Select

Press ▲▼ keys to set Over Voltage Trip. Range: 110-125% of Un (can not be set below Under Voltage), Off.

**OVERVOLT. TRIP
120% of Un**

Press Select

Press ▲▼ keys to set Over Voltage Trip time delay.

Range: 1-10 sec.

**OVERVOLT DELAY
2 SEC.**

Press Select

**STORE ENABLE
MAIN PARAMETERS**

Press **Store** Key to store selected parameters.

Note: Storing selected parameters is possible only when stop or run LED are on. Storing cannot be done when start, soft stop or fault LED is on.

When parameters have been correctly stored the LCD displays

DATA SAVED OK

This concludes Main & Protection Parameter settings.

Pressing **Select** key after "Data Saved OK" returns to the first display in this mode.

In case of a failure in parameter storing the LCD displays.

STORAGE ERROR

Press **Select** button again until "Store Enable Main Parameters" returns then press **Store** key until "Data Saved OK" appears.

Parameter Settings

Press Mode

To Advance to:

START PARAMETERS

Press Select

SOFT START CURVE
1 (STANDARD)

Then press ▲▼ keys to set Soft Start Curve:

- 0 = Basic
- 1 = Standard Curve
- 2!! = Pump Control Curve # 1
- 3!! = Pump Control Curve # 2
- 4!! = Pump Control Curve # 3
- 5!! = Torque Control

When setting dip switch # 2 to on for Tacho Mode

Press and curve message changes to:

START TACHO. GAIN
0 (MIN. GAIN)

Then press ▲▼ keys to set Tacho gain:

- 0 = Minimum gain tacho control.
- 1!! = Second level Tacho gain.
- 2!! = Third level Tacho gain.
- 3!! = Fourth level Tacho gain.
- 4!! = Fifth level Tacho gain.
- 5!! = Sixth level Tacho gain.

Note: Tacho feedback is operational in its basic form. Additional curves except for the basic linear curve are optional. Consult factory for correct tacho selection and mechanical installation.

Press Select,

Press ▲▼ keys to set Pulse Level.

Range: 70-700% of motor FLA. If Pulse Time is longer than 1 sec then max value of pulse level is limited to $440 \times (\text{STARTER FLC} / \text{MOTOR FLA}) [\%]$

PULSE LEVEL
70% OF FLA

Press Select,

Press ▲▼ keys to set Pulse Time.

Range: 0-10 sec.

PULSE TIME
0 SEC.

Note: Pulse Start has no effect with Start Curve = 0

Press Select,

Press ▲▼ keys to set Initial Voltage.

Range: 10-50% of Un for voltage ramp.

INITIAL VOLTAGE
30%

If you use curve 0 or 1 it is possible to increase the current within the range 100-400% of In.

The display changes to:

INITIAL CURRENT
100% OF FLA

Press Select,

Press ▲▼ keys to set Current Limit

Range: 100-400% of motor FLA.

CURRENT LIMIT
400% OF FLA

Press Select

Press ▲▼ keys to set Acceleration Time

Range: 1-30 sec.

ACC. TIME
10 SEC.

Press Select

Press ▲▼ keys to maximum Start Time.

Range: 1-30 sec.

MAX. START TIME
30 SEC.

Press Select

Press ▲▼ keys to set the number of starts permitted (during START period below)

Range: 1-10, Off.

NUMBER OF STARTS
1

Press Select

Press ▲▼ keys to set number of starts time period.

Range: 1-60 min.

STARTS PERIOD
20 MIN.

Press Select

Press ▲▼ keys to set start inhibit period

Range: 1-60 min.

START INHIBIT
15 MIN.

Press Select

Press ▲▼ keys to set time delay for the end of acceleration contact.

Range: 0-120 sec.

RUN CONTACT DEL.
5 SEC.

Press Select

To store selected parameters, press Store key.

STORE ENABLE
START PARAMETERS

When parameters have been correctly stored the LCD reads:

DATA SAVED OK.

This includes **START PARAMETERS** settings.

Parameter Settings

Press Mode

To advance to

STOP PARAMATERS

Press Select

Then press ▲▼ keys to set Soft Stop Curve

- 0 = Basic
- 1 = Standard Curve
- 2!! = Pump Control Curve # 1
- 3!! = Pump Control Curve # 2
- 4!! = Pump Control Curve # 3
- 5 = Torque Control Curve

SOFT STOP CURVE
1 (STANDARD)

When setting dip sw. # 2 to on for Tacho Mode,
Press ▲▼ and curve message changes to:

STOP TACHO GAIN
0 (MIN GAIN)

Then press keys to set Tacho gain:

- 0 = Minimum gain tacho control.
- 1!! = Second level tacho gain.
- 2!! = Third level tacho gain.
- 3!! = Fourth level tacho gain.
- 4!! = Fifth level tacho gain.
- 5!! = Sixth level tacho gain.

Note: Tacho Feedback is operational in its basic form. Additional curves except for the basic linear curve are optional. Consult factory for correct tacho selection and mechanical installation.

Press Select

Then press ▲▼ keys to set Deceleration Time.
Range: 0-30 sec.

DEC. TIME
0 SEC.

Press Select

Then press ▲▼ keys to set Final Torque during Soft Stop.

Range: 0 – 10 (0 = min., 10 = max.)

FINAL TORQUE
0 (MIN)

Press Select

To store selected parameters, press **Store** key

STORE ENABLE
STOP PARAMETERS

When parameters have been correctly stored the LCD displays:

DATA SAVED OK

This concludes **STOP PARAMETERS** setting.

Press Mode

To advance to Dual Adjustments when Dip Switch # 1 is set to ON:

DUAL ADJUSTMENT
PARAMETERS

When selecting “Generator Mode” (Dip sw # 3 is On) the following display appears instead of the above.

D. ADJ: GENERATOR
PARAMETERS

Press Select

Then press ▲▼ keys to set DA Initial Voltage.
Range: 10-50% of U_n with initial current 100% - 400%.

DA: INIT. VOLT.
30%

Press Select

Then press ▲▼ keys to set DA Current Limit.
Range: 100-400% of motor FLA.

DA: CUR. LIMIT
400% OF FLA

Press Select

Then press ▲▼ keys to set DA Acceleration Time.
Range: 1-30 sec.

DA: ACC. TIME
10 SEC.

Press Select

Then press ▲▼ keys to set DA Deceleration Time.
Range: 0-30 sec.

DA: DEC. TIME
0 SEC.

Press Select

Then press ▲▼ keys to set DA Motor FLA
Range: 33-100% of “STARTER FLC”

DA: MOTOR FLA
150 AMP.

Press Select

To store selected parameters, press **Store** key

STORE ENABLE
D.ADJ. PARAMETERS

When parameters have been correctly stored the LCD displays:

DATA SAVED OK

This concluded **DUAL ADJUSTMENT PARAMETERS** setting.

Parameter Settings

Press Mode

Set Dip Switch # 1 to ON to advance to:

FAULT PARAMETERS

Press Select

Then press ▲▼ keys to set Auto.Reset for Under-Voltage and Phase loss faults. Range: Yes/No.

UV & PL AUTO RST
NO

Press Select

Then press ▲▼ keys to set Under Current Auto Reset.

Range: 10-120min / Off

UNDER CUR. RESET
OFF

Press Select

Then press ▲▼ keys to set By Pass open trip. Range: Enable\ Disable.

BY PASS OPEN TRIP
ENABLE

Press Select

Then press ▲▼ keys to set trip after By Pass. Range: Enable\ Disable.

Can be used to disable most of fault protections starting 30 seconds after by-pass is closed. Use only if another protection relay is used.

TRIP AFTER BY PASS
ENABLE

Press Select

Then press ▲▼ keys to set By Pass auto reset. Range: Yes \ No.

BY PASS AUTO RESET
NO

Press Select

Then press ▲▼ keys to enable or disable “SET CURVE 0 FLT”.

Range: Enable\ Disable.

Set to disable, only if “SET CURVE TO 0” fault occurs during starting and if curve 0 starting process is not good enough for the application.

When set to disable verify that motor starts normally in the selected curve.

SET CURVE 0 FLT
ENABLE

Press Select

Then press ▲▼ keys to set Powe On and no start protection. Range: Enable\ Disable.

PWR ON & NO STRT
ENABLE

Press Select

Then press ▲▼ keys to set Insulation alarm level.

Range: Off, 0.2 – 20Mohm

INSULATION ALARM
OFF

Press Select

Then press ▲▼ keys to set Insulation alarm trip.

Range: Off, 0.2 – 20Mohm

INSULATION TRIP
OFF

Press Select

To store selected parameters press **Store** key

STORE ENABLE
FAULT PARAMETERS

When parameters have been correctly stored, the LCD displays:

DATA SAVED OK

This concludes **FAULT PARAMETERS** setting.

Parameter Settings

Press Mode

Set Dip Switch # 1 to ON, to Advance to:

**I/O PROGRAMMING
PARAMETERS**

Press Select

Then press ▲▼ keys to set Terminal # 7 function
Range: Test or Reset.

**PROG. INPUT # 7
RESET**

Press Select

Then press ▲▼ keys to set Terminal # 8 function
Range: Dual Adjustments, Reset

**PROG. INPUT # 8
DUAL ADJUSTMENT**

Press Select

Then press ▲▼ keys to set Fault Relay function
Range: Fault, Fault – Fail Safe

**FAULT RELAY TYPE
FAULT**

Press Select

Then press ▲▼ keys to set Immediate Relay function
Range: Immediate, Shear-Pin

**IMM / S.PIN RELAY
IMMEDIATE**

Press Select

Then press ▲▼ keys to set Imm / S. Pin Relay On
Delay.
Range: Immediate 0-60 sec. / Shear-Pin 0-5 sec.

**RELAY ON DELAY
0 SEC.**

Press Select

Then press ▲▼ keys to set Imm / S. Pin Relay Off
Delay.
Range: Immediate 0-60 sec. / Shear-Pin 0-5 sec.

**RELAY OFF DELAY
0 SEC.**

Press Select

Then press ▲▼ keys to set Normal or Inverted output.
Range: Normal, Inverted

**ANALOG OUTPUT
NORMAL**

Press Select

To store selected parameters, press **Store** key

**STORE ENABLE
I / O PROG. PARAM.**

When parameters are correctly stored the LCD displays

DATA SAVED OK

This concludes **I/O PARAMETER** setting.

Press Mode

Set Dip Switch # 1 to ON, to Advance to:

COMM. PARAMETERS

Communication is optional and operates only when
starter incorporates this feature.

Note: Hardware and software are installed in the
factory.

Note: The last command determines the function
when using communication and local
commands.

**Protocol is factory set to the correct one according
to installed hardware.**

**COMM. PROTOCOL
MODBUS**

For PROFIBUS parameters see page 30.

Press Select

Then press ▲▼ keys to set Communication Baud Rate.
Range: 1200-9600 BPS

**BAUD RATE
9600**

Press Select

Then press ▲▼ keys to set Communication Parity
Check. Range: Even / Odd

**PARITY CHECK
EVEN**

Press Select

Then press ▲▼ keys to set Communication Serial Link
Number
Range: 1-248 (for up to 32 starters on one twisted pair)

**SERIAL LINK NO.
248 (OFF)**

Note: Serial link number must be set to 248 (Off) if
communication is not in use.

To store selected parameters press **Store** key

**STORE ENABLE
COMM. PARAMETERS**

When parameters have been correctly stored the LCD
displays:

DATA SAVED OK

This concludes **COMMUNICATION
PARAMETERS** setting.

Parameter Settings

Press Select

Then press ▲▼ keys to set the protocol:

COMM. PROTOCOL
PROFIBUS

For MODBUS parameters see page 29.

Press Select

Then press ▲▼ keys to set number of input bytes to be scanned.

Range: 2, 4, 6, ...32

NO. OF IN BYTES
2

Press Select

Then press ▲▼ keys to set number of outputs.

Range: 1,2.

Where:

1 indicates no control via profibus. (only monitoring)

2 indicates full control via profibus

NO. OF OUT BYTES
1

Press Select

Then press ▲▼ keys to set Communication Serial Link Number

Range: 1-127 (for up to 32 starters on one twisted pair)

SERIAL LINK NO.
127 (OFF)

Note: Serial link number must be set to 127 (Off) if communication is not in use.

Press Select

To store selected parameters press **Store** key

STORE ENABLE
COMM. PARAMETERS

When parameters have been correctly stored the LCD displays:

DATA SAVED OK

This concludes **COMMUNICATION PARAMETERS** setting.

Parameter Settings

Press Mode

To advance to

STATISTICAL DATA

Note: It is possible to scroll with the arrow buttons.

Press Select

LAST STRT PERIOD
NO DATA

Displays last starting time in seconds. (Time duration until motor's current reached nominal)

Press Select

LAST START MAX I
NO DATA

Displays the maximum current at last starts.

Press Select

TOTAL RUN TIME
0 HOURS

Displays the motor runs time in hours since commencement or since "Statistical Data" was last reset.

Press Select

TOTAL # OF START
0

Displays the total numbers of starts since commissioning or since "Statistical Data" was last reset.

Press Select

LAST TRIP
NO DATA

Describes last fault.

Press Select

TRIP CURRENT
0% OF FLA

Displays the current at the last fault.

Press Select

TOTAL # OF TRIPS
0

Displays the total numbers of trips since commencement or since "statistical Data" was last reset.

PREVIOUS TRIP - 1

Through

PREVIOUS TRIP - 9

Press Mode to return to Display Mode

I1	I2	I3
0	0	0 %

Service Mode

Press **Mode** and  simultaneously. The LCD displays:

STORE ENABLE
DEFAULT PARAMET.

Press Store and **Mode** simultaneously to store factory Default Parameters. All previously stored parameters will be erased. This also returns to "Display Only" Mode.

To reset Statistical Data:

Press Select

RESET STATISTICS

Press Reset and **Store** simultaneously to reset all your statistical data. This also returns automatically to Statistical Data Mode.

Press Select to see the software program version

Displays program version

PROGRAM VERSION
MVSTRT.GN - 230706

For factory calibration:

Press Select

Read phase to phase main voltage in % of Un.

VOLTAGE ADJUST.
XXX % of Un

Press Select

Reads current. For factory calibration use only.

CURRENT ADJUST.
XXX% OF FLC

Press Select

Display goes back to Store Enable Default Parameters

STORE ENABLE
DEFAULT PARAMET.

To exit "Service Mode" **press Mod**  simultaneously.

Notes:

- Entering "Service Mode" is possible only when Stop LED is On.
- A start signal exists from this mode while in "Service Mode".

Note: It is necessary to connect a **motor** to load terminals otherwise "Wrong Connection" protection is activated. Other loads such as light-bulbs, resistors etc. may also cause "Wrong Connection" Fault.

Start-up Procedure

Start-up procedure with start-stop buttons (Use COMMISSIONING AND OPERATION MANUAL)

1. Connect Control Supply. **On** and **Stop** LED will light on.
2. Review all parameters with **Mode** and **Select** keys.
Set parameters as required.
3. If necessary, return to Default Parameters (see “Service Mode” page 31).
4. Connect main voltage to starter line terminals.
5. Set LCD to show “MOTOR FLA” (% of motor FLA).
6. Press Start. If motor starts to turn shortly after start signal, proceed to paragraph 7. If not, increase “Initial Voltage” setting and start again.
If initial inrush current and mechanical shocks during starting are too high, decrease “Initial Voltage” settings and proceed to paragraph 7.
7. Motor begins to turn. If speed accelerates smoothly to nominal, proceed to Para 8. If current during acceleration is too high, decrease “Current Limit” setting and proceed to Para 8. If motor speed does not accelerate to nominal, increase Current Limit setting.
8. Press Stop and wait until motor stops.
9. Slightly increase Initial Voltage and Current Limit settings to allow for load changes.
10. Press Start and see that the motor acceleration time to full speed is as required.
11. If acceleration time is too short, increase “Acceleration Time” setting.
12. Check total starting time and set Max. Start Time to approximately 5 seconds longer than the maximum time required to complete starting process.

Examples of starting curves Light Loads-Pumps, Fans, etc.

Initial Voltage (IV) – set to 30% (Factory Default)
Current Limit (CL) – set 300%
Acceleration Time (AT) – set 5 sec.

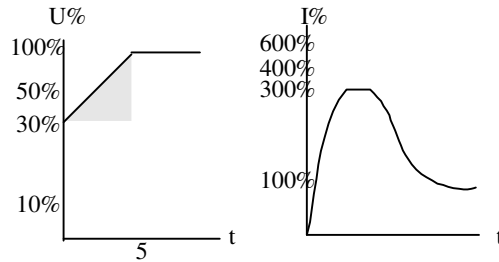

The voltage quickly increases to the Initial Voltage value and then gradually ramps-up to nominal. The current simultaneously and smoothly increases to reach Current Limit setting or less, before smoothly decreasing to the operating current. Motor speed will accelerate to full speed quickly and smoothly.

High Inertia Loads – Fans, Centrifuges, etc

Initial Voltage – set 50%
Current limit – set 400%
Acceleration time – set 20 sec

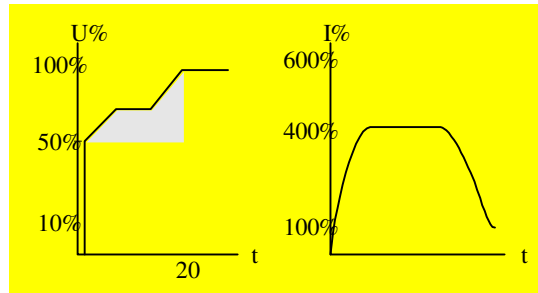

Voltage and current increase until current reaches “Current Limit”. The voltage is held at this value until motor is close to nominal speed, then current will begin to decrease. The HRVS-DN continues to ramp-up the voltage until reaching nominal. Motor speed smoothly accelerates to full speed.

Special starting – Using Dual Adjustment

Using two starting characteristics, the starter will accelerate to DA-IV reaching 100% current limit. After tx (Imm. Relay delay) voltage to terminal 8 is switched off, using the standard characteristic to complete acceleration. Useful to prevent initial high acceleration in applications such as submersible pumps, drum fans with resonating frequency, etc.

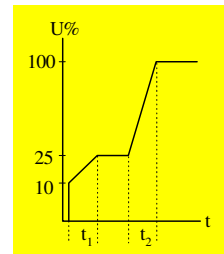

	Dual Adjust Para.	Standard Para.
Initial Voltage	10%	25%
Acceleration Time	T1 = 2-30 sec	T2 = 2-30 sec
Current Limit	200%	300-400%
Imm.Rel. ON delay	Tx = 1-60 sec.	-----

Menu Description

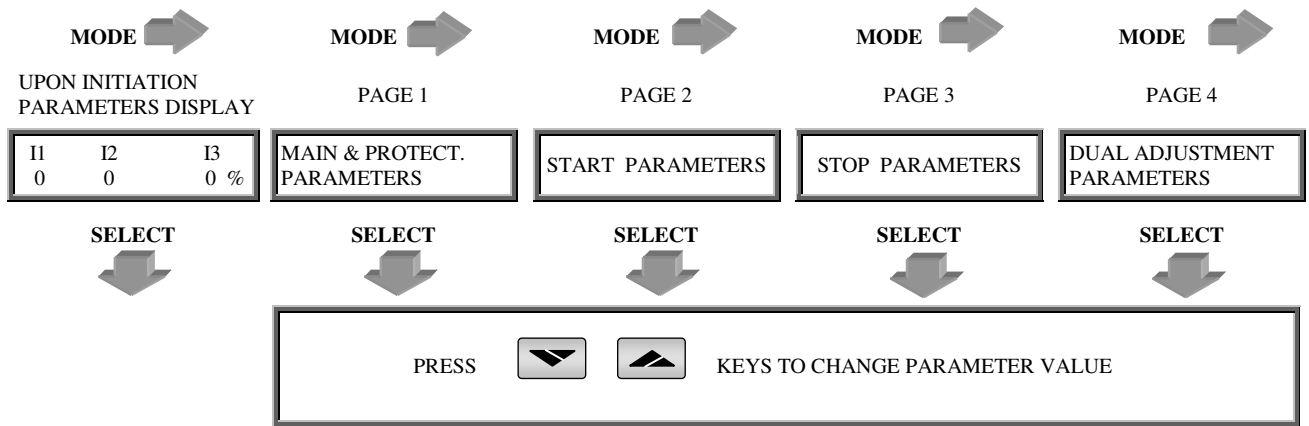

I1 0	I2 0	I3 0 A	STARTER FLC 150 AMP	SOFT START CURVE 1 (STANDARD)	SOFT STOP CURVE 1 (STANDARD)	DA: INIT. VOLT. 30%
OPTION CARD NOT INSTALLED			MOTOR FLA 150 AMP	PULSE LEVEL 70% OF FLA	DEC. TIME 0 SEC.	DA: CUR. LIMIT 400% OF FLA
			UNDERCURREN. TRIP 0% OF FLA	PULSE TIME 0.0 SEC.	FINAL TORQUE 0 (MIN).	DA: ACC. TIME 10 SEC.
			UNDERCURREN. DELAY 10 SEC	INITIAL VOLTAGE 30%	STORE ENABLE STOP PARAMETERS	DA: DEC. TIME 0 SEC.
			O/C – SHEAR PIN 850% OF FLA	***INITIAL CURRENT 100% OF FLA		DA: MOTOR FLA 150 AMP.
			O/C DELAY 0.5 SEC	CURRENT LIMIT 400% OF FLA		STORE ENABLE D. ADJ/ PARAMETERS
			OVERLOAD TRIP 115% OF FLA	ACC. TIME 10 SEC.		
			OVERLOAD DELAY 4 SEC. – AT 5 FLA	MAX START TIME 30 SEC.		
			UNBALANCE TRIP 20%	NUMBER OF STARTS 1		
			UNBALANCE DELAY 5 SEC.	STARTS PERIOD 20 MIN.		
			GND FAULT TRIP 20% OF FLA	START INHIBIT 15 MIN.		
			GND FAULT DELAY 5 SEC.	RUN CONTACT DEL. 5 SEC.		
			UNDERVOLT. TRIP 70% OF Un	STORE ENABLE START PARAMETERS		
			UNDERVOLT. DELAY 5 SEC.			
			OVERVOLT. TRIP 120% OF Un.			
			OVERVOL. DELAY 2 SEC.			
			STORE ENABLE MAIN & PROTECT.			

*** The display will be change automatically when initial voltage will increase over 50% of Un

Menu Description

MODE	MODE	MODE	MODE	MODE
PAGE 5	PAGE 6	PAGE 7	PAGE 8	PAGE 9
FAULT PARAMETERS	I/O PROGRAMING PARAMETERS	COMM. PARAMETERS	STATISTICAL DATA - -	FIRING TEST DISCONNECT MAINS
SELECT	SELECT	SELECT	SELECT	SELECT

Not Applicable	PRESS			KEYS TO CHANGE PARAMETER VALUE
-----------------------	-------	---	---	--------------------------------

Note:

Program input # 7 to test than store.
Connect control power to terminal 7 not 3 PHASE
Time is limit to 30 sec.

FOR MODBUS

UV & PL AUTO RESET NO	PROG. INPUT # 7 RESET	COMM/ PROTOCOL MODBUS	LAST STRT PERIOD X SEC.	FIRING PWR SUPPLY CHECK GREEN LED
UNDER CUR. RESET OFF	PROG. INPUT # 8 DUAL ADJUSTMENT	BAUD RATE 9600	LAST START MAX I X % OF FLA	FIRING NOW CHECK GREEN & RED LEDS
BY-PASS OPEN TRIP ENABLE	FAULT RELAY TYPE FAULT	PARITY CHECK EVEN	TOTAL RUN TIME 0 HOURS	FIRING NOW CHECK ALL LEDS OF R & S
TRIP AFTER BY-PASS ENABLE	IMM / S. PIN RELAY IMMEDIATE	SERIAL LINK NO. 248 (OFF)	TOTAL # OF START 0	FIRING NOW CHECK ALL LEDS OF S & T
BY-PASS AUTO RST NO	RELAY ON DELAY 0 SEC.	STORE ENABLE COMM. PARAMETERS	LAST TRIP NO DATA	FIRING NOW CHECK ALL LEDS OF R & T
SET CURVE 0 FLT ENABLE	RELAY OFF DELAY 0 SEC.	FOR PROFIBUS	TRIP CURRENT 0% OF FLA	
PWR ON & NO STRT ENABLE	ANALOG OUTPUT NORMAL	NO. OF IN BYTES 2	TOTAL # OF TRIPS 0	
INSULATION ALARM OFF	STORE ENABLE I/O PROG. PARAM.	NO. OF OUT BYTES 1	PREVIOUS TRIP-1 NO DATA	
INSULATION TRIP OFF		SERIAL LINK NO. 127 (OFF)	PREVIOUS TRIP-2 NO DATA	
STORE ENABLE FAULT PARMETERS		STORE ENABLE COMM. PARAMETERS	PREVIOUS TRIP-9 NO DATA	

Menu Description

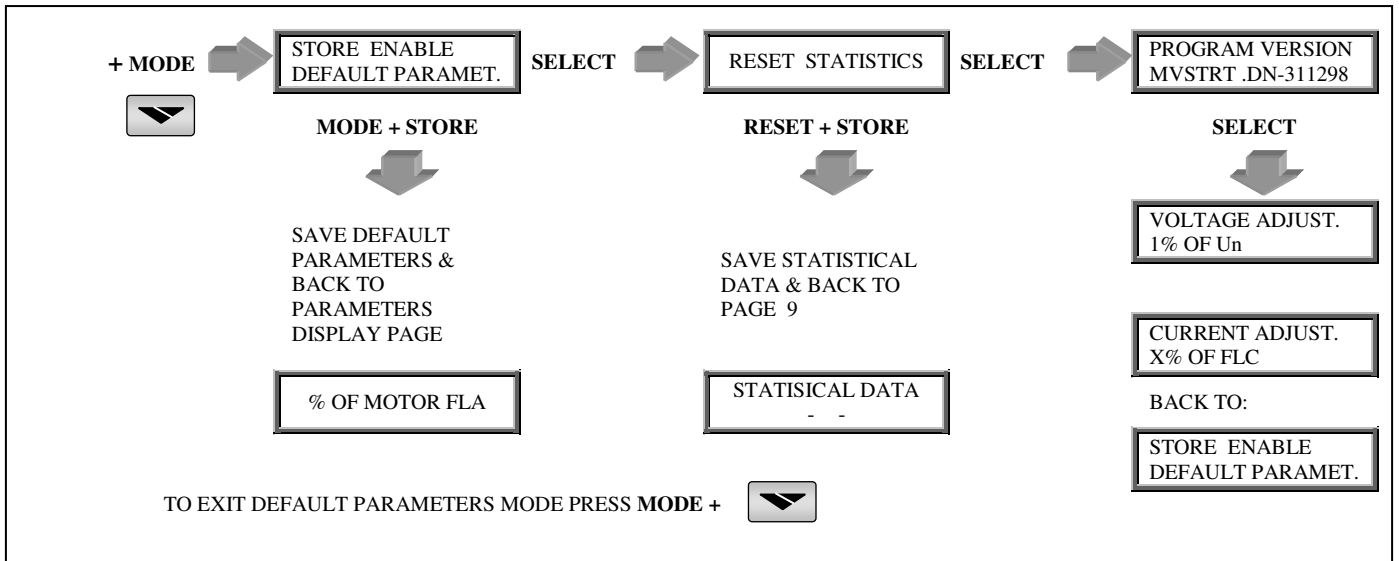

Trouble Shooting

Upon fault – motor stops. Fault LED light on and Fault Relay operates. The LCD shows TRIP and fault description.
Upon Alarm – motor continues running. Alarm Relay operates and Fault LED flashes. The LCD shows ALARM and fault description.

UNBALANCE TRIP	Current Unbalance is the difference between maximum and minimum values of motor three line currents divided by motor maximum current or motor FLA, whichever is greater. Fault occurs when the actual Unbalance is greater than the setpoint for more than “Unbalance Delay”.
GND FAULT TRIP	It operates when Ground Current exceeds the preset “GND FAULT TRIP” for more than “GND FAULT DLY”.
PWR ON & NO START	It operates upon main voltage connection and activated when main voltage is connected to the HRVS-DN for more than 30 seconds without a start signal.
BY-PASS OPEN	It operates when the by-pass contactor did not close after EOA contact of the HRVS-DN closes. Note: This protection can be disabled by setting By Pass open trip to disable when the By Pass is connected in a separate in a separate cabinet such that the starter CT’s do not measure motor current when the By Pass contactor is closed.
TOO MANY STARTS	Trips the starter if number of starts during “Start Period” exceeds the preset number. You have to wait until the motor and the starter cool down according to “Start Inhibit” setting.
LONG START TIME	Trips the starter if output voltage does not reach nominal at the preset max. start time. Check FLA, FLC, and max. start time settings. Increase Initial Voltage, Current Limit & max. start time or decrease acceleration Time as necessary.
O/C – SHEAR PIN	Trips the starter: <ol style="list-style-type: none">1. Instantaneously when current exceeds 8.5 x Starter FLC.2. If current exceed 8.5 x Motor FLA during starting with adj. delay.3. If current exceed 100-850% during running with adj. delay. <p>O/C Shear-Pin has a programmable delay of 0-5 seconds where the starter detects the fault and does not trip before time delay has elapsed (delay is overridden when current reaches 8.5 x Starter FLC). Check that motor is not installed or Jammed. Check FLA, FLC settings. Check motor and cable connections. Perform a “Megger” test to verify motor and cables condition</p>
OVERLOAD	Trips the starter when current exceed the Overload Trip level and thermal register has filled up. Check FLA, FLC and Overload settings, check the motor current, wait 15 minutes to let the motor and the starter to cool down before restarting.
UNDER CURRENT	Trips the starter when line current drops below the preset level for the preset time. Check “Under Current Trip” and “Time Delay” settings and check line currents through L ₁ , L ₂ and L ₃ .
UNDER VOLTAGE	Trips the starter when line voltage drops below the preset level for the preset time. Check “Under Voltage Trip “ and “Time Delay” settings and check the line voltages on L ₁ , L ₂ and L ₃ . When voltage drops to zero, the starter trips immediately with no delay.
OVER VOLTAGE	Trips the starter when line voltage increases above a preset level for a preset time. Check “Over Voltage Trip” and “Time Delay” settings. Check line voltage on L ₁ , L ₂ and L ₃ .

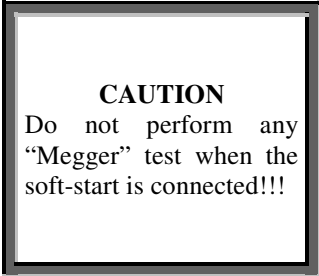

Trouble Shooting

PHASE LOSS	Trips the starter if 1 or 2 phases are missing. Check lines voltages and correct connection (see page 4).
PHASE SEQUENCE	Trips the starter if line phase sequence is wrong. Check line phase sequence. If wrong, swap two wires on <u>line</u> side. If motor now rotates in the wrong direction, swap two wires on <u>load</u> side. Note: Consult factory if phase sequence has to be reversed in the field.
WRONG CONNECTION or SHORTED SCR	Trips the starter when one or more motor phases is not connected to starter load terminals or in case of internal disconnection in motor winding. If required, may be eliminated by using dip switch # 3 and wiring the soft-starter in generator mode (programming D.A. parameters accordingly*).
S.SCR OR W.CON	Trips the starter and prevents starting if any SCR is short circuited or when motor windings are shorted or when firing is incorrect (fiber optic lead incorrectly inserted may cause this fault). Check with an ohmmeter between L ₁ -U, L ₂ -V, L ₃ -W; resistance > 20 KΩ Check for no voltage on terminals U, V, W (from parallel system or an independent by-pass). SCRs may fail due to: * High short current not protected by proper fuses. * High voltage spikes not protected by proper external Varistors. * Frequent starting at maximum conditions or fault conditions.
OVER TEMPERATURE	Heat-sink over-temperature trips the starter when heat-sink temperature rises above 85°C. Improve cooling or use a by-pass control. Check that motor starting is not too frequent.
EXTERNAL FAULT 1&2	Trips the starter when a N.O contact between terminals 19-21 closes for over two seconds. Check contact position and cause of closure.
WRONG PARAMETERS	Parameters not transferred from RAM to EEPROM or vice versa. After replacing the EPROM with a new software version or after power up, press Reset , than Mode and  simultaneously and save the default parameters by pressing Store and Mode simultaneously. (If Fault LED is on, press Reset after storing parameters).
SET CURVE TO 0	Trip occurs if the Soft Starter start with non-adequate starting curve to the network. Change start and stop parameter to curve 0 store the data and try again.
* NOTES:	Upon any fault read carefully the COMMISSIONING AND OPERATION MANUAL before you try to identify the cause.

Technical Specification

General Information:

Supply Voltage	Line to Line 2,300V, 3,300V, 4,160V, 6,000V, 6,600V, 6,900V, 11,000V, 13,800V (other voltages TBD) + 10%-15%
P.I.V ratings	For 2,300V PIV is 6,900V; For 3,300V PIV is 12,500V; For 4,160V PIV is 12,500V; For 6,600V PIV is 19,500V; For 11,000V PIV is 39,000V; For 13,800V PIV is 41,000V
Frequency	45 – 65 Hz (with frequency automatically change)
Control Supply	110-230V (to be specified) +10% - 15% 110VDC
Control inputs & Outputs	Either same as Control Supply or by special order 24-230V AC/DC (to be specified)
Load	Three phases, three wire, squirrel cage induction motor Synchronous motor with asynchronous starting characteristics.

Start-Stop Parameters:

Starter FLC	Starter Full Load Current according to Selector Guide
Motor FLA	Motor Full Load Ampere 33-100% of starter FLC
Pump Control Curves	6 field selectable curves including torque control curve preventing over-pressure during start and water hammer during stop.
Pulse Start Level and Duration.....	Adjustable level of pulse, for an adjustable time 0-10 Sec, for starting high friction loads or holding constant current level.
Initial Voltage.....	10-50% Un (*5-85%), 5% - by special order
Initial Current	for current ramp
Current Limit.....	100-400% of Motor FLA (*100-700%)
Acceleration Time	1-30 Sec (*1-90 sec)
Deceleration Time	0-30 Sec (*1-90 sec, not in Dual Adjust)
Dual Adjustments	Secondary start stop characteristic for: Motor FLA, Initial Voltage, Current Limit, Acceleration Time and Deceleration Time.
Tacho and Linear Acceleration	12 field selectable curves – defining Tacho Feedback gain improving linearity.

Motor Protection:

Too many starts	Maximum number of starts range Off or 1-10, during a time period 1-60 min.
Starts inhibit	Time period 1-60 min, where starting is prevented, after too many starts fault.
Long start time (Stall protection)	Maximum allowable starting time 1-30 sec. (*1-250 Sec).
Over current (Shear-pin)	Two operation functions: during starting trips the starter at 850% and during running at 100-850% In, both within 1 Cycle.
Electronic overload (I^2t)	Adjustable 75-150% of motor FLA, adjustable trips time at 500% In for 1-10 sec.
Under current	Trips when current drops below 20-90% In with time delay of 1-40 sec.
Under voltage**	Trips when main voltage drops below 50-90% of Un. Time delay 1-10 Sec
Over voltage	Trips when main voltage increases above 110-125% of Un. Time delay of 1-10 sec.
Phase loss	Trips when one or two phases are missing.
Phase sequence.....	Trips when phase sequence is wrong.
Wrong connection & Shorted SCR....	Prevents starting, trips if motor is not connected / incorrectly connected to the starter or in case one or more SCRs have been shorted.
Heat-sink over temp.	Trips when heat-sink temperature rises above 85°C.
External fault 1	Trips when an external contact closes for 2 sec.
External fault 2	Trips when an external contact closes for 2 sec.
Unbalance Current.....	Trips when Current Unbalance exceeds preset value for more than “Unbalance delay”
Ground Fault Current.	Trips when Ground Fault Current exceeds preset level for more than “Gnd Fault Delay”
Power ON & No Start	Trips when three phases voltage is connected to the soft-starter input and start signal was not issued for more than 30 seconds.
By-Pass Open ****	Trips if the by-pass contactor and one or two if its phases did not close.

* Special settings, extended range – consult factory

** With optional Auto Reset

*** Future enhancement

**** Can be disable

Technical Specification

Control:

DisplaysLCD in 4 – Field selectable languages and 8 LEDs
Keypad6 keys for easy setting
Aux. Contact – Immediate1 C/O, 8A, 250VAC, 2000VA
Aux. Contact – End of Acceleration1 C/O, 8A, 250VAC, 2000VA
Fault Contact.....1 C/O, 8A, 250VAC, 2000VA
Communication.....RS 485 with MODBUS or PROFIBUS protocols

TemperaturesOperating -10° to 50°C
Storage -20° to 70°C

Enclosure:

Degree of ProtectionIP 00 - Chassis type
IP 32 - Standard
IP 54 – Optional
PaintRAL 7032 – standard
Other colors - optional

Normal Service Conditions:

AltitudeShould not exceed 1000m.
Consult factory for equipment to be used at higher altitudes.
Humidity95% Non condensed

Starter Consumption Ratings (for chassis type)

Peak consumption350VA during start process and less than 20 VA otherwise